



6000 ESP

Installation Guide



table of contents

What Is Included	3	Shock Sensor Harness, 4-Pin Connector	23
Installation Points to Remember	4	Internal Programming Jumper	24
Deciding on Component Locations	5	Light Flash Jumper	24
Siren	5	Bypassing Sensor Inputs	25
Control Module.	5	System Features Learn Routine	26
Shock Sensor	6	Once a Feature is Programmed	27
Valet/Program Switch	7	To Access Another Feature in	
Status LED	7	the Same Menu	27
Starter Kill Relay	8	To Select Another Menu	27
Finding the Wires You Need	8	To Exit the Learn Routine	27
Obtaining Constant 12V	8	System Features Menus	28
12V Switched Ignition Wire	8	Menu #1-Basic Features	28
Starter Wire.	9	Menu #2-Advanced Features	28
Door Pin Switch Circuit	9	Feature Descriptions	29
Making Your Wiring Connections	10	Menu #1-Basic Feature Descriptions	29
Primary Harness (H1), 12-Pin Connector	11	Menu #2-Advanced Feature Descriptions	30
Primary Harness (H1) Wire Connection Guide	11	Transmitter/Receiver Learn Routine	32
Door Lock Harness (H2), 3-Pin Connector	16	Transmitter Configurations	34
Door Lock Harness (H2) Wire Connection Guide	17	Standard Configuration.	34
Positive-Triggered, Relay Driven		Single Button Arm/Disarm Configuration	34
Systems (Type A)	17	Multi-Level Security Arming	35
Negative-Triggered, Relay Driven		Table of Zones	35
Systems (Type B)	18	Long-Term Event History	36
Reversing Polarity (Type C)	19	Optional Vehicle Recovery System	36
After-market Actuators (Type D)	20	To Arm VRS	36
Electrically Activated Vacuum (Type E)	21	To Disarm VRS	37
One-Wire System, (Type F)	22	Rapid Resume Logic	37
Plug-In Harnesses	22	Troubleshooting	38
Super Bright LED	22		
Valet®/Program Switch.	22		
Programmer Interface	23		

Bitwriter™, Code Hopping™, DEI®, Doubleguard®, ESP™, FailSafe®, Ghost Switch™, Learn Routine™, Nite-Lite®, Nuisance Prevention Circuitry®, NPC®, Revenger®, Silent Mode™, Soft Chirp®, Stinger®, Valet®, Vehicle Recovery System®, VRS®, and Warn Away® are all Trademarks or Registered Trademarks of Directed Electronics, Inc.

what is included

- The control module (see diagram)
- Two 476 Series four-button remote transmitters
- A plug-in status LED
- A plug-in Valet®/Program switch
- A plug-in Stinger® shock sensor
- A Revenger® Soft Chirp® siren

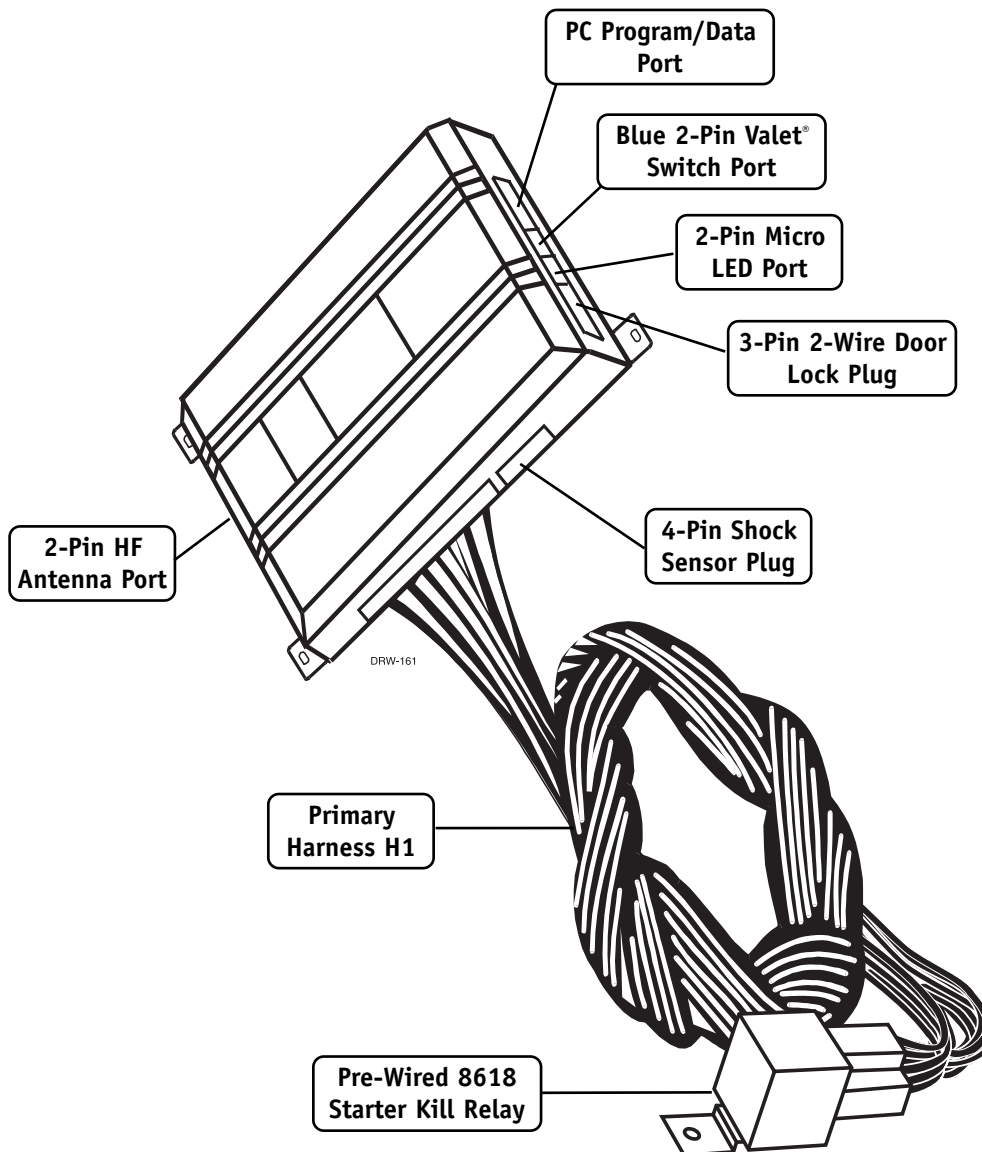

installation points to remember

This product represents many years of research and development. It is very sophisticated and should be installed by experienced security installers only. Please do not attempt installation of this product without reading this guide. The system has been designed to provide the ultimate in security, coupled with limitless convenience and expansion options.

This product is not intended for consumer installation and will have NO WARRANTY unless it is installed by an authorized dealer.

Do not disconnect the battery if the vehicle has an anti-theft coded radio. If equipped with an air bag, avoid disconnecting the battery if possible.

***IMPORTANT!** Many airbag systems will display a diagnostic code through their warning light after they lose power. Disconnecting the battery requires this code to be erased, a procedure that can require a trip to the dealer.*

Before beginning the installation:

- Check with the customer on Status LED location.
- Remove the domelight fuse. This prevents accidentally draining the battery.
- Roll down a window to avoid being locked out of the car.

After the installation:

- Test all functions. The “Using Your System” section of the Owner’s Guide is very helpful when testing.
- When testing, don’t forget that this system is equipped with Nuisance Prevention® Circuitry. NPC™ can bypass both instant trigger zones, making them seem to stop

deciding on component locations

locations for the siren

Some things to remember about mounting the siren:

- Keep it away from heat sources, such as radiators, exhaust manifolds, turbochargers, and heat shields.
- Mount it where a thief cannot easily disconnect it, whether the hood is open or shut. Both the siren and its wires should be difficult to find. This usually involves disguising the wire to look like a factory harness.
- We recommend against grounding the siren to its mounting screws. Instead, we recommend running both the red and black wires into the passenger compartment and grounding to one common point for all devices. After all, both wires are the same length and come already bonded together. Whenever possible, conceal your wires in the factory harnesses or in the same style loom as the factory.
- When possible, place the siren on the same side of the vehicle as the control module, where its wires will reach the control module's wires without extending them. Always run the wires through the center of a grommet, never through bare metal!
- Point the siren down so water does not collect in it.

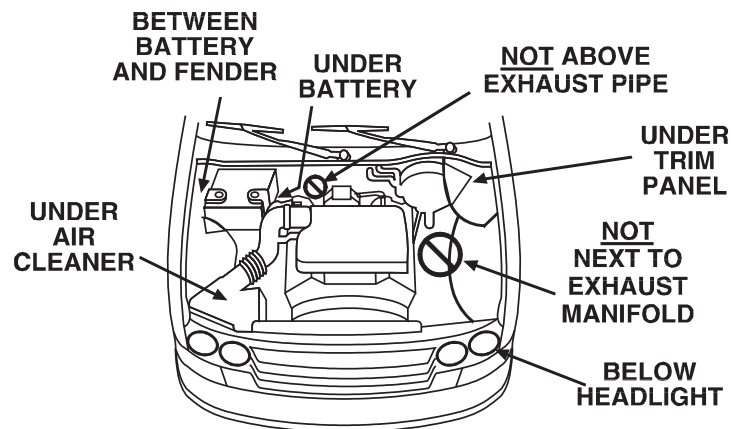

locations for the control module

Some things to remember about where to mount the control module:

- Never put the control module in the engine compartment!
- The first step in hot-wiring a vehicle is removing the driver's side under-dash panel to access the starter and ignition wires. If the control module is placed just behind the driver's side dash it can easily be disconnected.
- When mounting the control module, try to find a secure location that will not require you to extend the harnesses' wires (they are 1.5 meters long). Keep it away from the heater core (or any other heat sources) and any obvious leaks.

- The higher the control module is in the vehicle, the better the transmitter range will be. If you put the control module under a seat or inside a metal dashboard, range will suffer, and you may wish to add a DEI® 542T Range Extending Antenna (available separately).

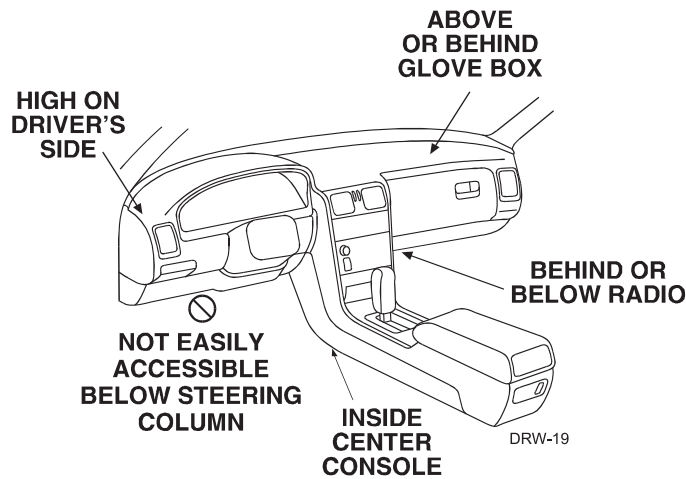

Some good control module locations: above the glove box, inside the center console, above the under-dash fuse box, above the radio, etc.

locations for stinger doubleguard shock sensor

Some things to remember about where to mount the shock sensor:

- Never put the Stinger® in the engine compartment!
- Find a spot close to the control module so that the wires do not need to be extended. Keep it away from the heater core (or any other heat sources) and any obvious leaks.

How the Stinger® is mounted is the most important factor in its performance. We recommend two methods:

- Using double-sided tape or hook-and-loop fastener to mount to a trim panel or an air duct, or
- Wire-tying to a wire harness.

If mounting the sensor where it cannot be easily reached for adjustment, hook-and-loop fastening tape (such as Velcro) is recommended for ease of removal for future adjustments.

NOTE: In many vehicles, tying the sensor to a steering column or screwing it to metal will result in poor sensitivity, especially at the rear of the vehicle.

locations for valet/program switch

IMPORTANT! When the vehicle is delivered, please show the user where this switch is located and how to disarm the system with it.

Ensure that the location you pick for the switch has sufficient clearance to the rear. The switch should be well hidden. It should be placed so passengers or stored items (such as in a glove box or center console) cannot accidentally hit it. The switch fits into a $\frac{9}{32}$ -inch hole.

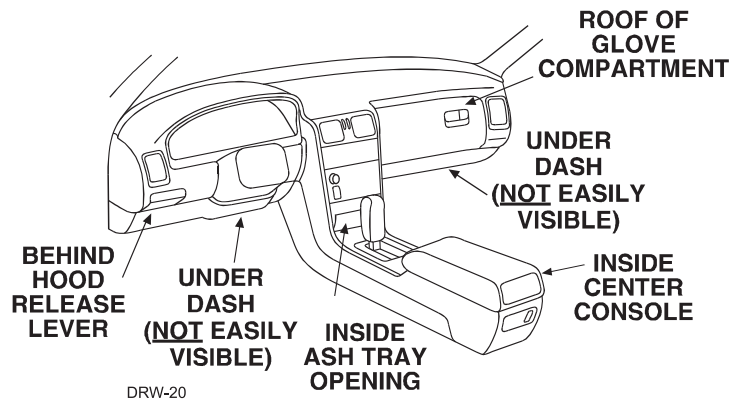

This system has Remote Valet®. The user can enter and exit Valet® Mode without having to reach the Valet®/Program switch. DEI introduced this feature so that switch location was less critical in day-to-day use. As long as the Valet®/Program switch can be reached to disarm without a transmitter, easy access is not important.

locations for the status LED

Things to remember when positioning the Status LED:

- It should be visible from both sides and the rear of the vehicle, if possible.
- It needs at least $\frac{1}{2}$ " clearance to the rear.
- It is easiest to use a small removable panel, such as a switch blank or a dash bezel. Remove it before drilling your $\frac{9}{32}$ " hole.
- Use quick-disconnects near the LED wires if the panel is removable. This lets mechanics or other installers remove the panel without cutting the wires.

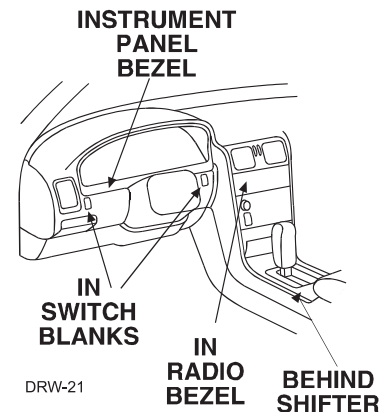

locations for the starter kill relay

If starter kill relay or its connections are immediately visible upon removal of the under-dash panel, they can easily be bypassed. Always make the relay and its connections difficult to discern from the factory wiring! Exposed yellow butt connectors do not look like factory parts, and will not fool anyone! For this reason, routing the starter kill wires away from the steering column is recommended.

finding the wires you need

Now that you have decided where each component will be located, you're going to find the wires in the car that the security system will be connected to.

IMPORTANT! Do not use a 12V test light to find these wires! Use a digital multimeter for all testing.

obtaining constant 12V

We recommend two possible sources for 12V constant: the (+) terminal of the battery, or the constant supply to the ignition switch. Always install a fuse within 12 inches of this connection. If the fuse also will be powering other circuits, such as door locks, a power window module, a Nite-Lite® headlight control system, etc., fuse accordingly.

IMPORTANT! Do not remove the fuse holder on the red wire. It ensures that the control module has its own fuse, of the proper value, regardless of how many accessories are added to the main power feed.

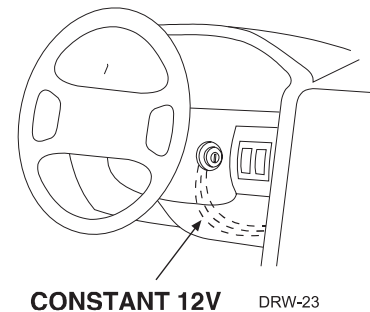
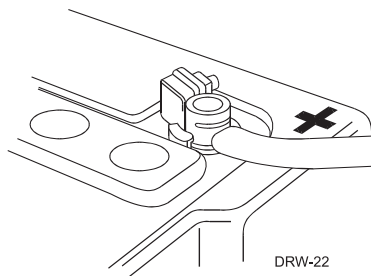
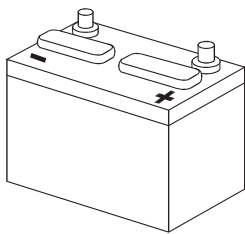

finding the 12V switched ignition wire

The ignition wire is powered when the key is in the run or start position. This is because the ignition wire powers the ignition system (spark plugs, coil) as well as the fuel delivery system (fuel pump, fuel injection computer). Accessory wires lose power when the key is in the start position to make more current available to the starter motor.

How to find (+)12V ignition with your multimeter:

1. Set to DCV or DC voltage (12V or 20V is fine).
2. Attach the (-) probe of the meter to chassis ground.
3. Probe the wire you suspect of being the ignition wire. The steering column harness or ignition switch harness is an excellent place to find this wire.
4. Turn the ignition key switch to the run position. If your meter reads (+)12V, go to the next step. If it doesn't, probe another wire.
5. Now turn the key to the start position. The meter display should stay steady, not dropping by more than a few tenths of a volt. If it drops close to or all the way to zero, go back to Step 3. If it stays steady at (+)12V, you have found an ignition wire.

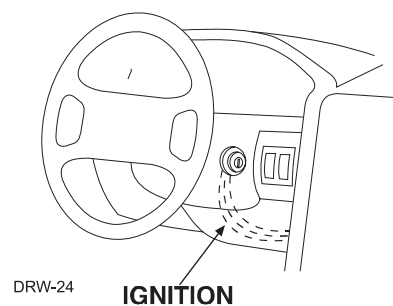

finding the starter wire

The starter wire provides 12V directly to the starter or to a relay controlling the starter. In some vehicles, it is necessary to power a cold start circuit. A cold start circuit will test exactly like a starter circuit, but it does not control the starter. Instead, the cold start circuit is used to prime the fuel injection system for starting when the vehicle is cold.

How to find the starter wire with your multimeter:

1. Set to DCV or DC voltage (12V or 20V is fine).
2. Attach the (-) probe of the meter to chassis ground.
3. Probe the wire you suspect of being the starter wire. The steering column is an excellent place to find this wire. Remember you do not need to interrupt the starter at the same point you test it. Hiding your starter kill relay and connections is always recommended.
4. Turn the ignition key switch to the start position. Make sure the car is not in gear! If your meter reads (+)12V, go to the next step. If it doesn't, probe another wire.
5. Cut the wire you suspect of being the starter wire.
6. Attempt to start the car. If the starter engages, reconnect it and go back to Step 3. If the starter does not turn over, you have the right wire.

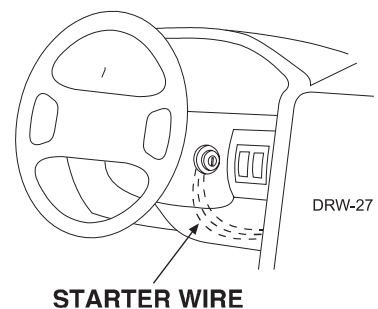

finding the door pin switch circuit

The best places to find the door switch wire are:

- At the pin switch: When testing at the pin switch, check the wire to ensure that it "sees" all the doors. Often, the passenger switch will cover all the doors even if the driver's switch will not.
- At the dome light: This may not be your best choice if the vehicle has delayed domelight supervision, but it will work in many Hondas, or any vehicle with completely diode-isolated pin switches.

Once you have determined the wire color, the easiest place to connect to the wire is often at the kick panel, at the windshield pillar, or in the running board. When an easy location is not available, running a wire to the dome-light itself is often the best solution.

How to find a door pin switch trigger wire with your multimeter:

1. Set to DCV or DC voltage (12V or 20V is fine).
2. In most Fords, fasten the (-) probe of the meter to chassis ground. In most other cars, fasten the (+) probe of your meter to (+)12V constant.
3. Probe the wire you suspect of being the door trigger wire. If the meter reads (+)12V when any door is opened, you have found a trigger wire.

making your wiring connections

Before making your connections, plan how your wires will be routed through the vehicle. For instance, the yellow ignition input, the red 12V constant input, and the orange ground-when-armed output (for the starter kill relay) will often be routed together to the ignition switch harness. In order to keep the wiring neat and make it harder to find, you may wish to wrap these wires together in electrical tape or conceal them in tubing similar to what the manufacturer used.

There are two acceptable ways of making a wire connection - solder connections and crimp connectors. When properly performed, either type of connection is reliable and trouble-free. Regardless of whether you solder your connections or you use mechanical-type crimp-on connections, ensure that all connections are mechanically sound and that they are insulated.

Cheap electrical tape, especially when poorly applied, is not a reliable insulator. It often falls off in hot weather. Use good-quality electrical tape or heat shrink.

- Never twist-and-tape the wires together without soldering.
- Never use "fuse taps", as they can damage fuse box terminals.

If you use tapping connectors such as 3M T-Taps (not to be confused with Scotch-Locks), avoid using them in higher-current applications (constant 12V, ground, etc.). Some tapping connectors are inferior in quality and should be avoided.

primary harness (H1), 12-pin connector

H1/1	ORANGE	(-) 500 mA ARMED OUTPUT
H1/2	WHITE	(+)/(-) SELECTABLE LIGHT FLASH OUTPUT
H1/3	WHITE/BLUE	(-) 200 mA CHANNEL 3 PROGRAMMABLE OUTPUT
H1/4	BLACK/WHITE	(-) 200 mA DOMELIGHT SUPERVISION OUTPUT
H1/5	GREEN	(-) DOOR TRIGGER INPUT, ZONE 3
H1/6	BLUE	(-) INSTANT TRIGGER INPUT, ZONE 1
H1/7	VIOLET	(+) DOOR TRIGGER INPUT, ZONE 3
H1/8	BLACK	(-) CHASSIS GROUND INPUT
H1/9	YELLOW	(+) SWITCHED IGNITION INPUT, ZONE 5
H1/10	BROWN	(+) SIREN OUTPUT
H1/11	RED	(+) CONSTANT POWER INPUT
H1/12	RED/WHITE	(-) 200 mA CHANNEL 2 OUTPUT

primary harness (H1) wire connection guide

This guide describes in detail the connection of each wire. Also included are possible applications of each wire. This system was designed with the ultimate in flexibility and security in mind. Many of the wires have more than one possible function. Please read carefully to ensure a thorough understanding of this unit.

H1/1 ORANGE (-) ground-when-armed output

This wire supplies a (-) ground as long as the system is armed. This output ceases as soon as the system is disarmed. The orange wire is pre-wired to control the 8618 starter kill relay. It can supply up to 500 mA of current.

NOTE: If connecting the orange wire to control another module, such as a 529T or 530T window module, a 1 amp diode (type 1N4004) will be required. (See following diagram.)

IMPORTANT! Never interrupt any wire other than the starter wire.

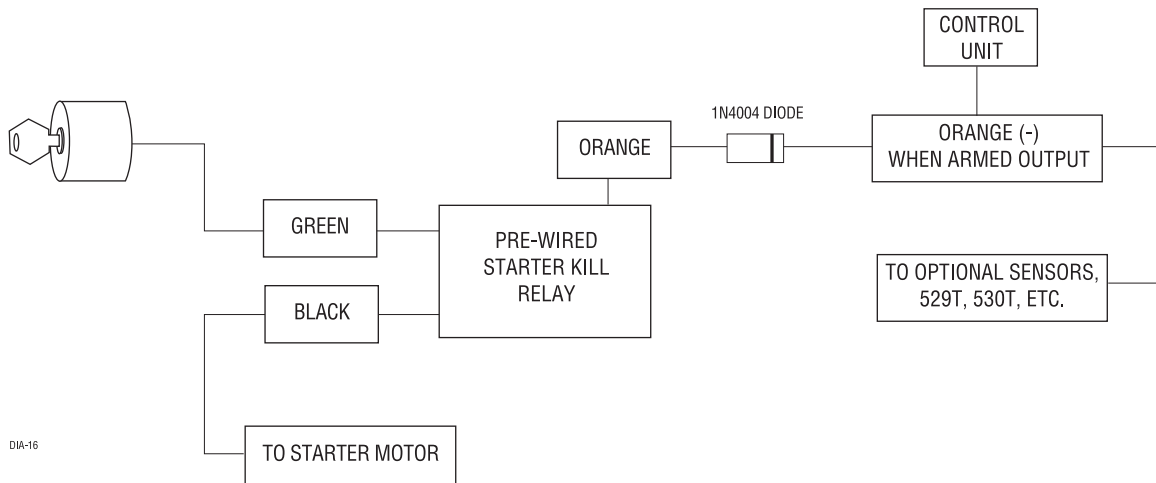

H1/2 WHITE light flash output

As shipped, this wire should be connected to the (+) parking light wire. If the light flash polarity jumper under the sliding door is moved to the opposite position (see *Internal Programming Jumpers* section of this guide), this wire supplies a (-) 200 mA output. This is suitable for driving (-) light control wires in Toyota, Lexus, BMW, some Mitsubishi, some Mazda, and other model cars.

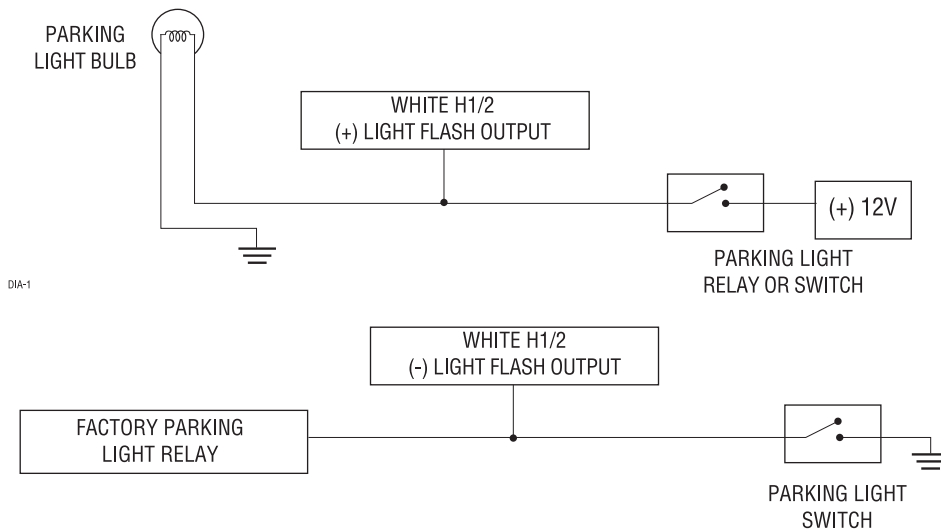

H1/3 WHITE/BLUE 200 mA (-) channel 3 output

This wire provides a 200 mA (-) output whenever the transmitter button(s) controlling channel three is pressed. This output can be programmed to provide the following types of output (see *System Features Learn Routine* section of this guide):

- A validity output will send a signal as long as the transmission is received.
- A latched output will send a signal continuously when channel three pressed and will continue until channel three is pressed again.
- A latched/reset with ignition output works similar to the latched output, but will also reset (output will stop) when the ignition is turned on and then off.
- A 30 second timed output will send a signal for 30 seconds when channel three is pressed. This output can be shut off during the 30-second period by pressing Channel 3 again.
- This output can also be programmed to provide a second unlock pulse when the disarm button is pressed within 15 seconds after disarming the system. This can be used to unlock the passenger doors when installing progressive door locks.

IMPORTANT! Never use this wire to drive anything but a relay or a low-current input! This transistorized output can only supply 200 mA, and connecting directly to a solenoid, motor, or other high-current device will cause the module to fail.

H1/4 BLACK/WHITE 200 mA (-) domelight supervision output

Connect this wire to the optional domelight supervision relay as shown below:

IMPORTANT! This output is only intended to drive a relay. It cannot be connected directly to the domelight circuit, as the output cannot support the current draw of one or more bulbs.

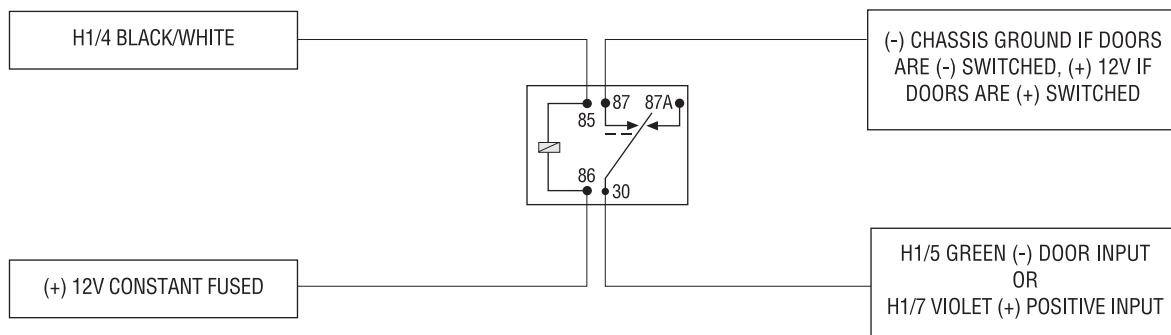

DJA-2

H1/5 GREEN (-) door trigger input

Most vehicles use negative door trigger circuits. Connect the green wire to a wire which shows ground when any door is opened. In vehicles with factory delays on the domelight circuit, there is usually a wire that is unaffected by the delay circuitry.

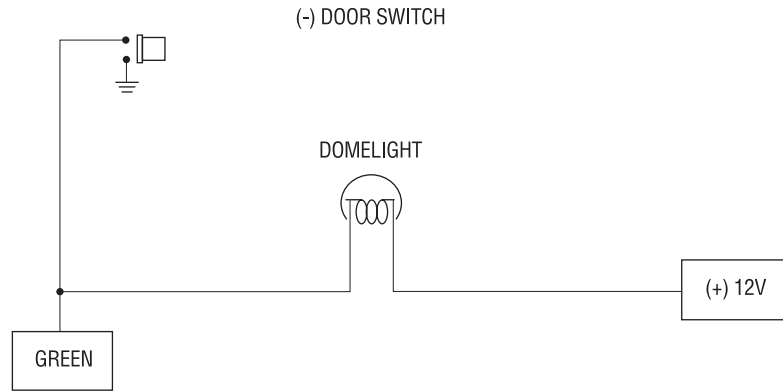

H1/6(-) instant trigger input, zone 1

This input will respond to a negative input with an instant trigger. It is ideal for hood and trunk pins and will report on zone one. It can also be used with 506T Glass Breakage Sensor, as well as other DEI® single stage sensors.

H1/7 VIOLET (+) door trigger input

This type of dome circuit is used in many Ford products. Connect the violet wire to a wire that shows (+)12V when any door is opened, and ground when the door is closed.

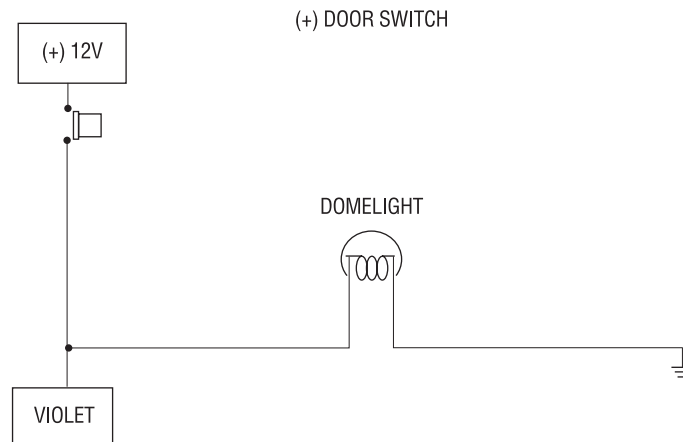

H1/8 BLACK (-) chassis ground connection

Connect this wire to bare metal, preferably with a factory bolt rather than your own screw. (Screws tend to either strip or loosen with time.) We recommend grounding all your components, including the siren, to the same point in the vehicle.

NOTE: Remove any paint below ring connector.

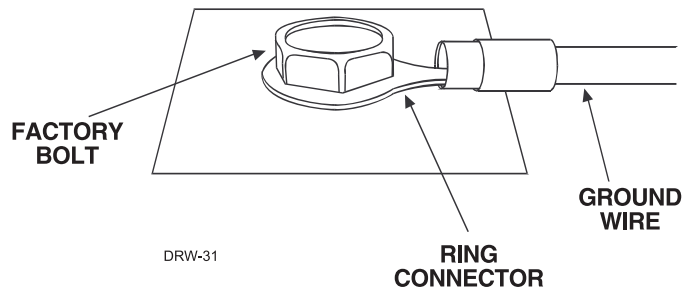

H1/9 YELLOW (+) ignition input

Connect this wire to the (+)12V ignition wire. This wire is pre-wired to the starter kill relay and must show (+)12V with the key in Run position and during cranking. Take great care that this wire cannot be shorted to the chassis at any point.

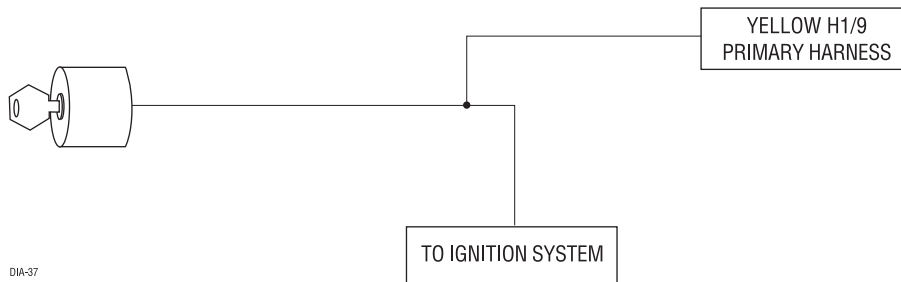

H1/10 BROWN (+) siren output

Connect this to the red wire of the Revenger® siren. Connect the black wire of the siren to (-) chassis ground, preferably at the same point you connect the control module's black ground wire.

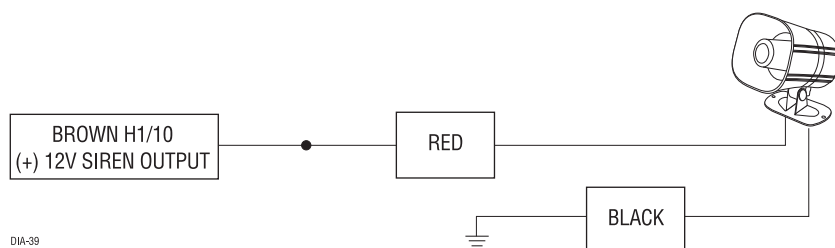

H1/11 RED (+)12V constant power input

Before connecting this wire, remove the supplied fuse. Connect to the battery positive terminal or the constant 12V supply to the ignition switch.

NOTE: Always use a fuse within 12 inches of the point you obtain (+)12V. Do not use the 10A fuse in the harness for this purpose. This fuse protects the module itself.

H1/12 RED/WHITE 200 mA (-) channel 2 output

When the system receives the code controlling channel 2 for longer than 1.5 seconds, the red/white will supply an output as long as the transmission continues. This is often used to operate a trunk/hatch release or other relay-driven function.

IMPORTANT! Never use this wire to drive anything but a relay or a low-current input! The transistorized output can only supply 200 mA of current. Connecting directly to a solenoid, motor, or other high-current device will cause it to fail.

door lock harness (H2), 3-pin connector

H2/A	GREEN	(-) LOCK, (+) UNLOCK OUTPUT
H2/B	EMPTY	UNLESS USING 451M
H2/C	BLUE	(-) UNLOCK, (+) LOCK OUTPUT

This system can control two common power door lock types without any additional parts! With certain vehicles, or if an actuator is to be installed, either a 451M Door Lock Relay Satellite or two relays will be required.

IMPORTANT! If you mistake a Type C direct-wired system for a Type A positive-pulse system, the module will be damaged!

door lock harness (H2) wire connection guide

type A: (+) 12V pulses from the switch to the factory relays

The system can control a Type A system directly, with no additional parts. The switch will have three wires on it, and one will test (+)12V constantly. The others will alternately pulse (+)12V when the switch is pressed to the lock or unlock position.

If you cannot get to the switch, and you find a set of wires that pulses (+)12V alternately on lock and unlock, you must take care to ensure that it is not a Type C direct-wire system.

Here is a test: Cut the wire which pulses (+)12V on lock, and then operate the switch to unlock. If all doors unlock, the vehicle uses a type A system. If you lose all door lock operation in both directions, you are operating the master switch in a Type C system.

If you lose all door lock operation of one or more doors, but not all motors stop operating, and other doors still work, you have cut a wire leading directly to one or more motors. You must instead find the actual wires leading to the switch.

Many domestically-made GM vehicles use Type A locks. However, many more GM vehicles are Type C than in previous years. The full-size pickups (1989-up), many of the S10 Blazers, the Corvette, 1995 Cavalier/Sunfire 1993 - and newer, and Camaro/Firebird all use Type C door locks, and cannot be controlled without a 451M! Almost all domestically-built Fords are Type C. Ford builds very few Type A systems. Chrysler builds both Type A and Type C, so use caution.

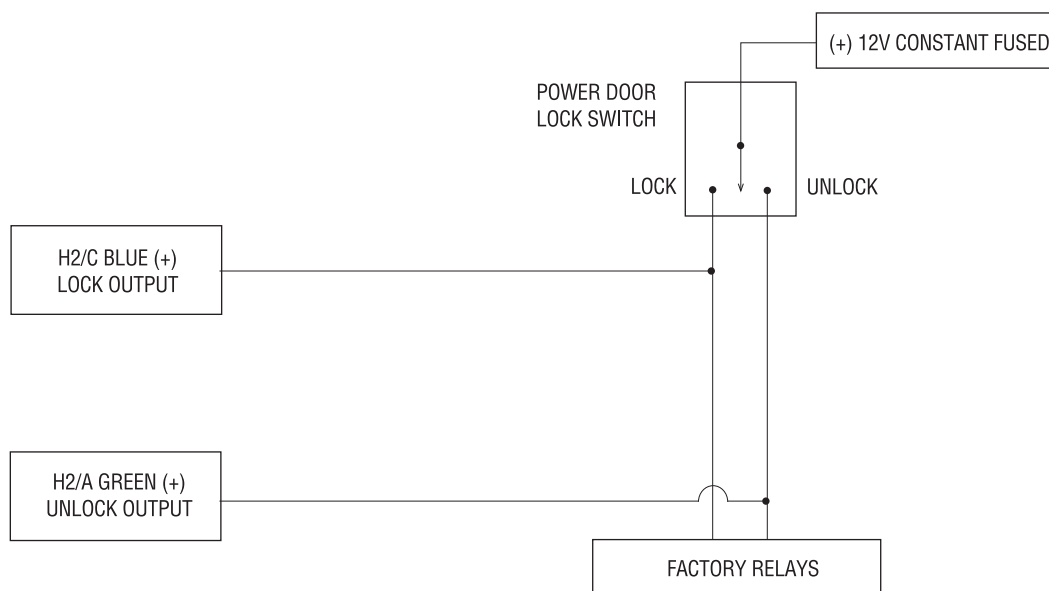

DIA-10

type B: (-) pulses from the switch to the factory relays

This system is common in many Toyota, Nissan, Honda, and Saturn models, as well as Fords with the keyless-entry system (some other Fords also use Type B).

The switch will have three wires on it, and one wire will test ground all the time. One wire will pulse (-) when the switch locks the doors, and the other wire will pulse (-) when the switch unlocks the doors. This type of system is difficult to mistake for any other type.

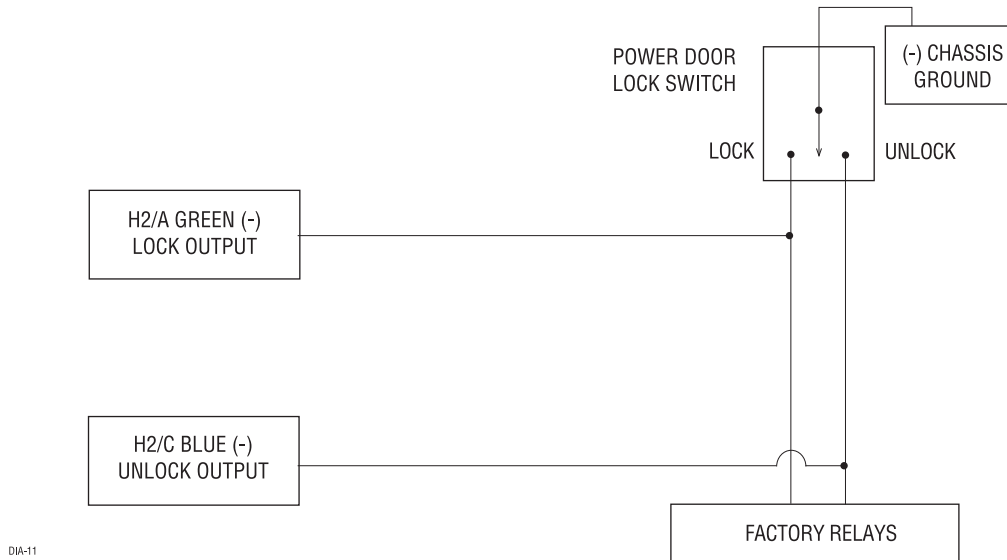

type C: reversing polarity

Interfacing with a reversing polarity system requires either two relays or one 451M (not included).

It is critical to identify the proper wires and locate the master switch to interface properly. Locate wires that show voltage on lock and unlock. Cut one of the suspect wires and check operation of the locks from both switches. If one switch loses operation in both directions and the other switch operates in one direction only, you have located one of the target wires. The switch that lost all operation is the master switch. If one switch works both directions and the other switch works only one direction, you have a Type A system. If both switches still operate, but one or more doors have stopped responding entirely, you have cut a motor lead. Reconnect it and continue to test for another wire. Once both wires have been located and the master switch identified, cut both wires and interface as shown below.

IMPORTANT! If these are not connected properly, you will send (+) 12 volts directly to (-) ground, possibly damaging the alarm or the factory switch.

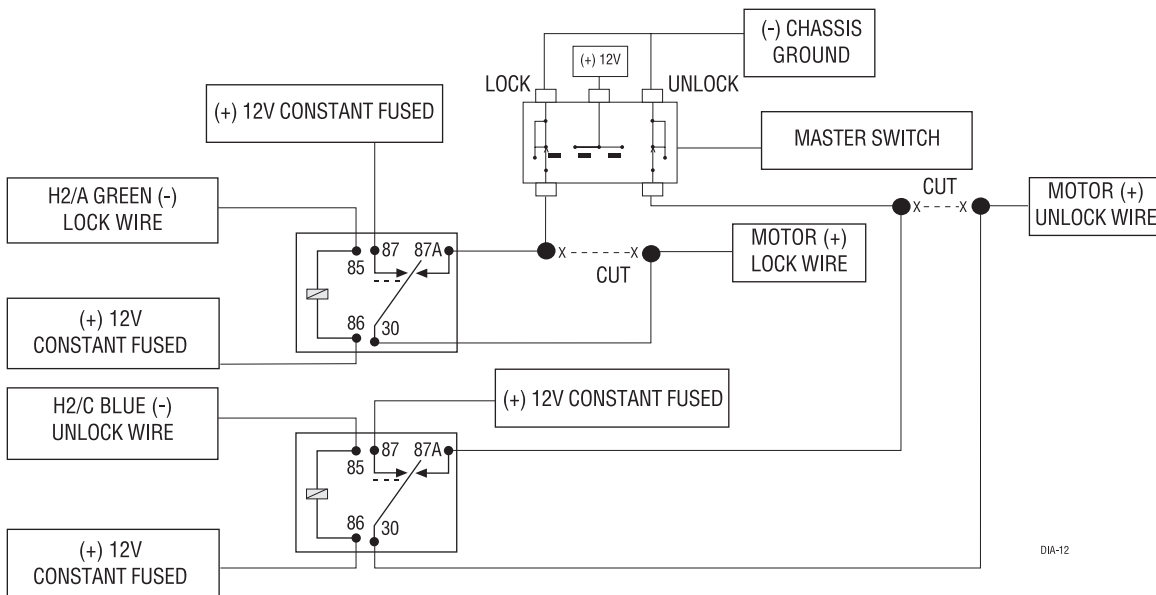

type D: after-market actuators

In order for this system to control one or more after-market actuators, a 451M or two relays (optional) are needed.

Vehicles without factory power door locks require the installation of one actuator per door. This requires mounting the door lock actuator inside the door. Other vehicles may only require one actuator installed in the driver's door if all door locks are operated when the driver's lock is used. This type of installation is required to operate factory lock systems in Volvo (except 850), SAAB, and most Mazda, Isuzu and Subaru models. The fuse used on 12-volt inputs should be 7.5A per motor installed in the vehicle.

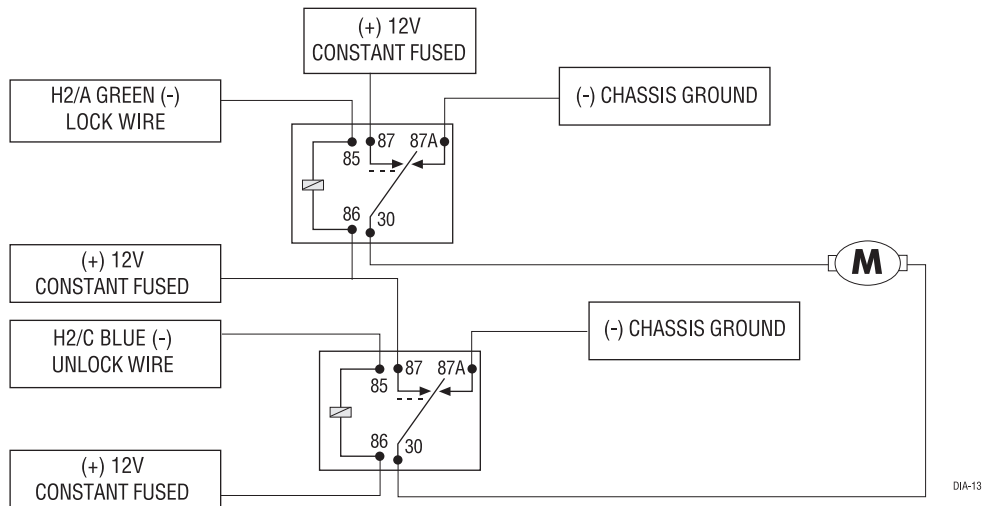

type E: mercedes-benz and audi (1985 and newer)

Door locks are controlled by an electrically activated vacuum pump. Some Mercedes and Audi models use a Type D system. Test by locking doors from the passenger key cylinder. If all the doors lock, the vehicle's door lock system can be controlled with just two relays (optional). The control wire can be found in either kick panel and will show (+)12V when doors are unlocked and (-) ground when doors are locked.

To interface, see diagram below. The system must be programmed for 3.5 second door lock pulses. (See *System Features Learn Routine* section of this guide.)

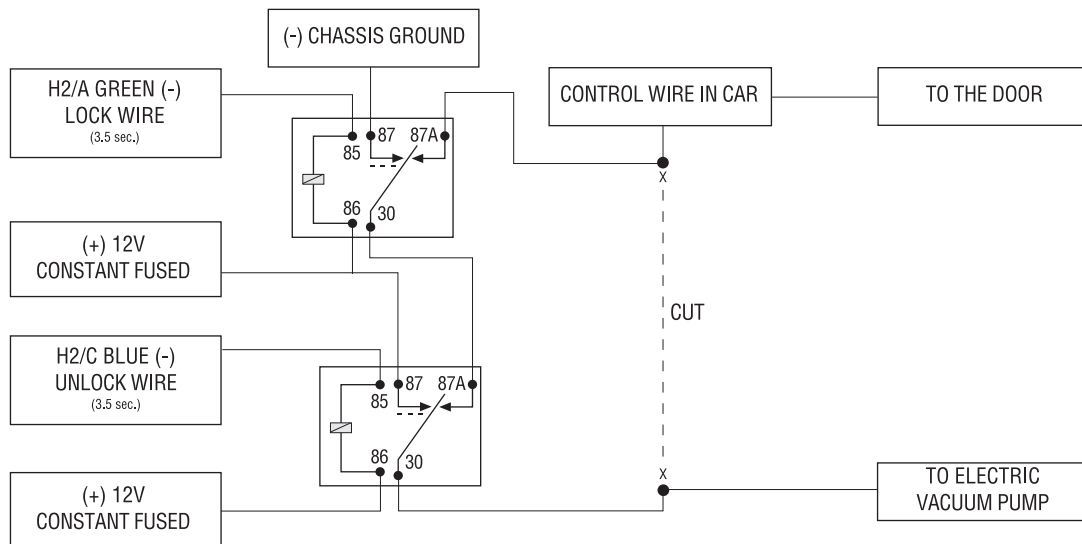

type F: one-wire system

This system usually requires a negative pulse to unlock, and cutting the wire to lock the door. In some vehicles, these are reversed. It is found in late-model Nissan Sentras, some Nissan 240SX, and Nissan 300ZX 1992 and later. It is also found in some Mazda MPV's and some Mitsubishi's.

One relay (optional) is used to interface to this type of system as follows:

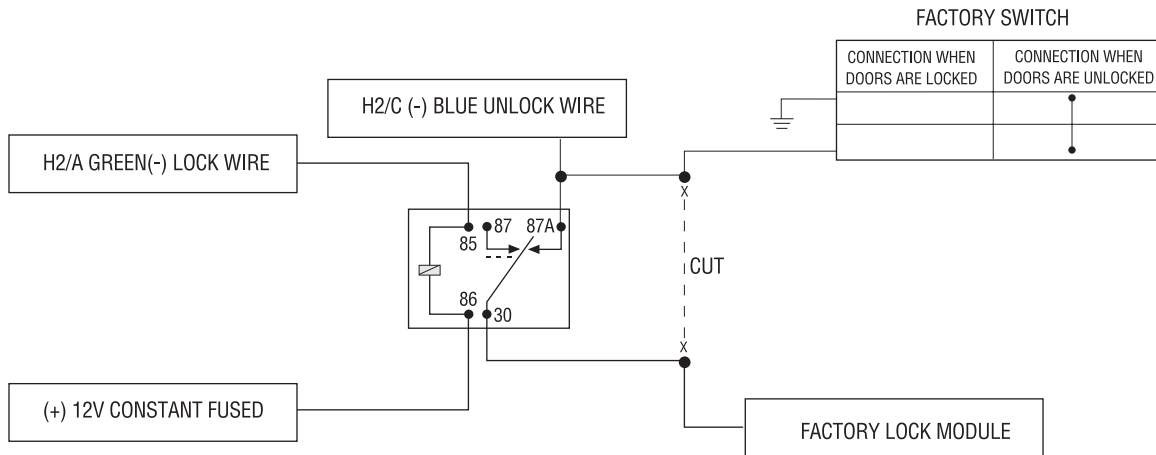

plug-in harnesses

super-bright LED, 2-pin white plug

The super bright LED operates at 2V DC. Make sure the LED wires are not shorted to ground as the LED will be damaged. Multiple LED's can be used, but they must be wired in series. The LED fits into a 9/32-inch mounting hole. Be sure to check for clearance prior to drilling the mounting hole.

valet/program switch, 2-pin blue plug

The Valet®/Program switch should be accessible from the driver's seat. It plugs into the blue port on the side of the unit. Since the system features Valet® by using the remote transmitter, the switch can be well hidden. Consider how the switch will be used before choosing a mounting location. Check for rear clearance before drilling a 9/32-inch hole and mounting the switch. The GRAY wire in the two-pin plug may also be used as a (+) ghost switch input and can be connected to any (+) switch in the vehicle. (See *Feature Descriptions* section of this guide.)

programmer interface, 3-pin black plug

The black three pin port is provided for personal computer programming of the unit. When using the DEI Bitwriter (P/N 998T) or optional PC Interface module (P/N 996T) it is possible to configure any and all of the programmable functions using an IBM-compatible personal computer. For more information please refer to the guide packaged with the programmer. This port can also be used to interface the Valet® Car★Com (DEI P/N 820T) with the security system.

shock sensor harness, 4-pin connector

GREEN (-) multiplex input

Inputs shorter than 0.8 seconds will trigger the Warn Away® response, while inputs longer than 0.8 seconds will trigger full alarm sequence and report zone four. If installing an optional DEI® dual stage sensor, connect to the green wire as shown below. The diagram below eliminates the need for diodes to isolate the sensors, as well as providing a separate zone for each sensor.

Diagram for adding optional DEI® dual stage sensor to green wire (zone 4)

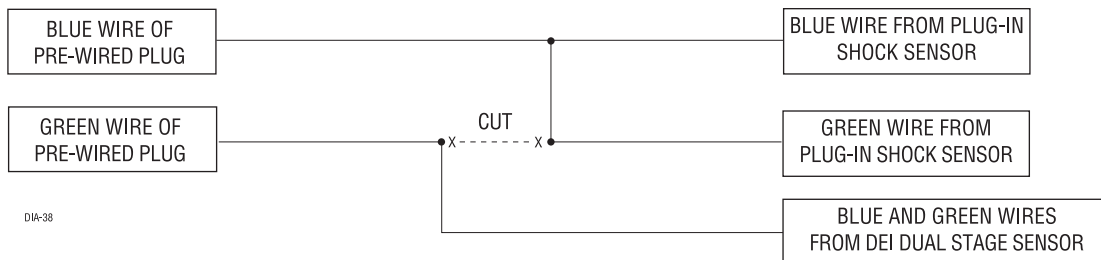

BLUE (-) multiplex input

Inputs shorter than 0.8 seconds will trigger the Warn Away® response, while inputs longer than 0.8 seconds will trigger full alarm sequence and report zone two.

RED (+) 12V constant and BLACK (-) ground

Do not use these for anything besides the plug-in shock sensor.

internal programming jumper

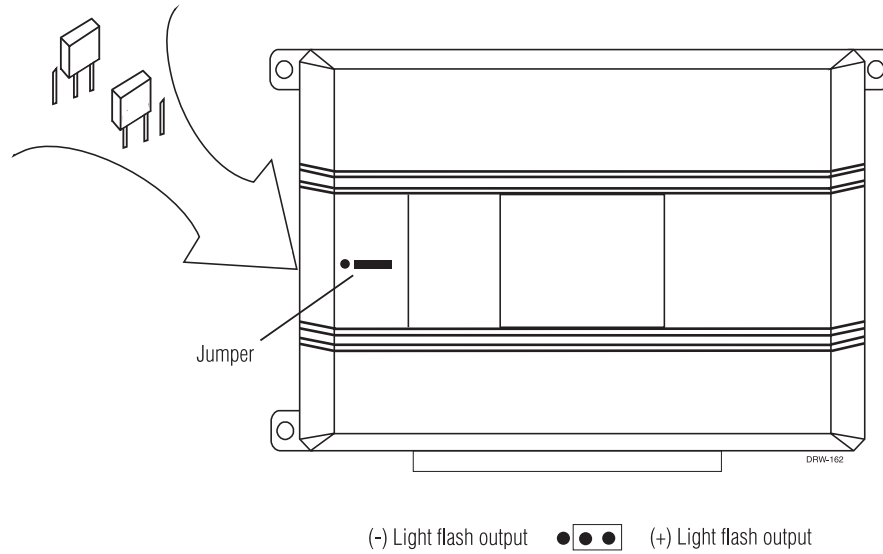

light flash jumper

This jumper is used to determine the light flash output. In the (+) position, the on-board relay is enabled and the unit will output (+)12V on the WHITE wire, H1/2. In the (-) position, the on-board relay is disabled. The WHITE wire, H1/2, will supply a 200 mA (-) output suitable for driving factory parking light relays.

bypassing sensor inputs

There are times when you need to temporarily bypass all sensor inputs to the unit, such as when remote starting the vehicle. Anytime an auxiliary channel output is used, all inputs are bypassed for 5 seconds. During the 5 second bypass period, ground can be supplied to the H1/6 Blue wire without triggering the unit. When the 5 second bypass period ends, if the unit sees ground on the H1/6 Blue wire, all trigger inputs except the door trigger input will remain bypassed until 5 seconds after ground is removed from the BLUE wire. This can be done using the status output of a 551T remote start unit as shown below:

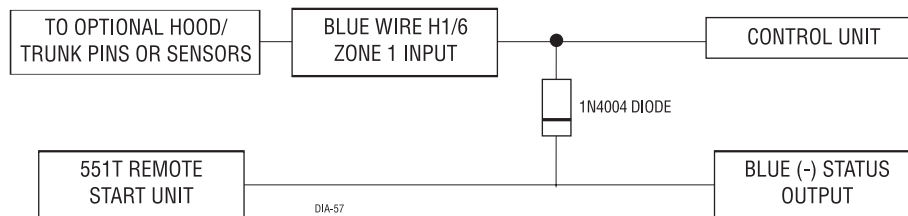

system features learn routine

The System Features Learn Routine™ dictates how the unit operates. Due to the number of steps, they have been broken up into two menus. It is possible to access and change any of the feature settings using the Valet®/Program switch. However, this process can be greatly simplified by using the optional DEI Bitwriter or Personal Computer Interface, P/N 996T. Any of the settings can be changed and then assigned to a particular transmitter, up to four, a feature called Owner Recognition. Each time that particular transmitter is used to disarm the system, the assigned feature settings will be recalled. Owner Recognition is only possible when programming the unit via the 996T or the 998T DEI Bitwriter.

Using the optional DEI Bitwriter or PC Interface, the learn routine may be locked. Make sure the learn routine is unlocked before programming features. If the siren generates one long chirp when attempting to program the unit, the learn routine is locked and must be unlocked using the DEI Bitwriter or PC before proceeding.



1. **Open a door:** (The H1/5 GREEN wire or the H1/7 VIOLET wire must be connected.)



2. **Ignition:** Turn the ignition on, then back off: (The H1/9 YELLOW wire must be connected.)



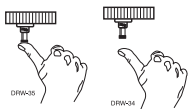

3. **Select a menu:** Press and HOLD the Valet®/Program button: (The Valet®/Program button must be plugged into the blue port.) After three seconds the siren will chirp once indicating entry to the Basic Features Menu #1. If this is the menu you wish to access, release the button and go on to step 4. If the button is not released, you will jump to the Advanced Features Menu #2 and the siren will chirp twice. Once you have selected the desired menu, release the Valet®/Program button and then go to step four.



4. **Select a feature:** Press and release the Valet®/Program button the number of times corresponding to the step you wish to change. For example, to access the third feature, press and release three times. Then press the button once more and HOLD it. The siren will chirp the number of times equal to the step you have accessed.



5. **Program the feature:** While holding the Valet®/Program button, you can toggle the feature on and off using the remote transmitter. Pressing  will select the one chirp or default setting. Pressing  will select the two chirp setting. (See *Transmitter/Receiver Learn Routine* section of this guide.)

*NOTE: The Valet® pulse count feature (2-5) and the Channel three timed output (2-9) have five possible settings each. Pressing **AUX** will toggle through all the possible settings.*



6. Release the Valet®/Program button.

once a feature is programmed

- Other features can be programmed within the same menu.
- Another menu can be selected.
- The learn routine can be exited if programming is complete.

to access another feature in the same menu

1. Press and release the Valet®/Program switch the number of times necessary to advance from the feature you just programmed to the next one you want to program.
2. Then press the Valet®/Program switch once more and hold it.

For example, if you just programmed the third feature in the menu and you would like to program the seventh feature in the menu, you would press and release the Valet®/Program switch four times and then press it once more and hold it. The siren would chirp seven times to confirm access to the seventh feature.

to select another menu

1. Press and hold the Valet®/Program switch.
2. After three seconds, the unit will advance to the next menu and the siren will chirp, indicating which menu has been accessed.

For instance, if you just programmed some features in Menu #1 (Basic Features) and you desire to program a feature in Menu #2, you press and hold the Valet®/Program button. After three seconds, the siren chirps twice indicating access to Menu #2.

to exit learn routine

To exit the System Features Learn Routine, do one of the following:

1. Close the open door.
2. Turn the ignition on.
3. No activity for longer than 15 seconds.
4. Press the Valet®/Program switch too many times.

system features menus

menu #1 - basic features

Items in bold text have been programmed to the two chirps setting at the factory.

FEATURE NUMBER	ONE-CHIRP SETTING (DEFAULT)	TWO-CHIRP SETTING
1-1	Active arming	Passive arming
1-2	Chirps on	Chirps off
1-3	Ignition-controlled door locks on	Ignition-controlled door locks off
1-4	Active locking only	Passive locking
1-5	Panic with ignition on	No panic with ignition on
1-6	0.8 second door lock pulses	3.5 second door lock pulses
1-7	Forced passive arming on	Forced passive arming off
1-8	Automatic engine disable on	Automatic engine disable off
1-9	Armed When Driving (AWD)	Vehicle Recovery System (VRS®)
1-10	Code Hopping™ on	Code Hopping™ off

menu #2 - advanced features

FEATURE NUMBER	ONE-CHIRP SETTING (DEFAULT)	TWO-CHIRP SETTING
2-1	Siren	Horn honk
2-2	30-second siren duration	60-second siren duration
2-3	Nuisance Prevention Circuitry™ on	Nuisance Prevention Circuitry™ off
2-4	Progressive door trigger	Instant door trigger
2-5	Valet switch input: 1 pulse	Valet switch input: 2-5 pulses
2-6	Door trigger error chirp on	Door trigger error chirp off
2-7	Ignition-controlled domelight on	Ignition-controlled domelight off
2-8	Single unlock pulse	Double unlock pulse
2-9	Channel 3: Validity	Channel 3: latched/latched, reset with ignition/30-second timed/second unlock output

feature descriptions

The features of the system are described below. If the system is being programmed with a DEI® Bitwriter™ or 996T and a personal computer the options available may change. PC programmable options are indicated by the following icon:



menu #1 - basic feature descriptions

1-1 ACTIVE/PASSIVE ARMING: When active arming is selected, the system will only arm when the transmitter is used. When set to passive, the system will arm automatically 30 seconds after the last door is closed. To alert the consumer of passive arming, the siren will chirp 20 seconds after the door is closed. This provides the consumer with an audible warning prior to the system actually arming. At the 30 second mark, the system will arm but the siren will not chirp.

1-2 CHIRPS ON/OFF: This feature controls the chirps that confirm the arming and disarming of the system.

 **1-3 IGNITION CONTROLLED DOOR LOCKS ON/OFF:** When turned on, the doors will lock three seconds after the ignition is turned on and unlock when the ignition is turned off. The TechSoft Programmer or the 998T Bitwriter™ will display separate steps for ignition lock and ignition unlock. They can be programmed on or off independently.

1-4 ACTIVE/PASSIVE LOCKING: If passive arming is selected in step 1-1, then the system can be programmed to either lock the doors when passive arming occurs, or only lock the doors when the system is armed via the transmitter. Active locking means the system will not lock the doors when it passively arms. Passive locking means that the system will lock the doors when it passively arms.

***NOTE:** Remember, when passive arming is selected, the unit will chirp 20 seconds after the last door is closed. The system does not actually arm or lock the doors until 30 seconds after the door has been closed.*

1-5 PANIC WITH IGNITION ON: This step controls whether or not the Panic Mode is available with the ignition on. In some states, there are laws prohibiting a siren from sounding in a moving vehicle. This feature makes the system compliant with these regulations.

1-6 DOOR LOCK PULSE DURATION: Some European vehicles, such as Mercedes-Benz and Audi, require longer lock and unlock pulses to operate the vacuum pump. Programming the system to provide 3.5 second pulses, will accommodate the door lock interface in these vehicles. The default setting is 0.8 second door lock pulses.

1-7 FORCED PASSIVE ARMING ON/OFF: To use this feature, passive arming must be selected in step 1-1. When turned on, forced passive arming will ensure that the system will passively arm, even if a zone is left open or invalid. Forced passive arming occurs one hour after the ignition is turned off.

1-8 AUTOMATIC ENGINE DISABLE (AED) ON/OFF: AED is a full-time, passive starter disable that works independently of the security system. When turned on, the orange, ground-when-armed output (H1/1) will go active 30 seconds after the ignition is turned off. The LED will flash at half its normal rate when the ignition is turned off to indicate that AED is active and will interrupt the starter in 30 seconds. AED does not occur in Valet® mode and can be bypassed using the emergency override procedure. The transmitter can be used to disarm AED; however, the system must be armed and then disarmed with the transmitter, in order to disarm AED.

1-9 ARMED WHILE DRIVING/VEHICLE RECOVERY SYSTEM: In the default setting (Armed While Driving), the system can be armed with the ignition on. When armed, the ground-when-armed is not active and the sensors are bypassed. The door triggers will remain active. If programmed to the Vehicle Recovery System (VRS®) setting, VRS will be activated.

1-10 CODE-HOPPING™ ON/OFF: The system uses a mathematical formula to change its code each time the transmitter and receiver communicate. This makes the group of bits or “word” from the transmitter very long. The longer the word is, the easier it is to block its transmission to the unit. Disabling the Code-Hopping™ feature lets the receiver ignore the Code-Hopping™ part of the transmitted word. As a result, the unit may have better range with Code-Hopping™ off.

menu #2 - advanced feature descriptions

2-1 SIREN/HORN HONK: The system can be programmed to output pulses instead of a continuous output when the system is triggered. This is useful to honk the factory horn in applications where a siren is undesirable. Remember that the unit is only capable of supplying 1 amp of current. A relay will be required to interface with most factory horn systems.



2-2 SIREN DURATION 30/60 SECONDS: It is possible to program the unit to sound for 30 or 60 seconds during the triggered sequence. Some states have laws regulating how long a security system can sound. When using the TechSoft Programmer or Bitwriter™, the siren can be programmed to sound for any length of time ranging from 1 to 180 seconds. Use the right and left arrows or the + and - keys on your keyboard to change the siren duration in 1 second intervals. Holding down the key will rapidly increase or decrease the setting. The desired siren duration can also be directly entered by using the number keys on your computer's keyboard.

2-3 NUISANCE PREVENTION® CIRCUITRY (NPC™) ON/OFF: NPC™ stops repeated triggering of the same zone. If one zone is triggered three times in one hour, that zone is bypassed for one hour, starting from the time of the third trigger. During that hour, if the system detects a trigger on that zone again, the system resets the one hour timer. If one hour passes and the zone has not triggered again, the zone is activated and can trigger the system again. NPC™ only monitors sensor inputs, and does not bypass the door trigger or the ignition trigger at any time. If NPC™ is turned off, the system will respond to repeated triggers on the sensor inputs and will do so indefinitely. Some states have laws regulating how many times a security system can trigger before it is considered a nuisance and the vehicle is towed away.

2-4 PROGRESSIVE DOOR TRIGGER ON/OFF: The system responds to a door trigger input with a progressive response. When the door is opened with the system armed, the siren will chirp 10 times prior to the full triggered sequence. The door trigger is still treated as an instant trigger and closing the door quickly will not prevent a full triggered sequence from occurring. If the progressive door trigger is programmed off, the full siren output will occur the moment the door is opened.

2-5 VALET PULSE COUNT 1 to 5 PULSES: The system can be programmed to count the number presses of the valet switch before disarming the security system or VRS®. The factory default setting is one pulse. The unit can be set for 2 to 5 pulses using the two-chirp setting to select the pulse count.

***GHOST SWITCH OPTION:** For added security, the GRAY wire on the two-pin Valet®/Program can be connected to any switch in the vehicle that provides a positive (+) momentary pulse.*

2-6 DOOR TRIGGER ERROR CHIRP ON/OFF: With the door trigger error chirp programmed off, the system will not report an invalid zone on arming when the door trigger wire is active. This eliminates the extra chirps that occur when interfacing with vehicles that have exceptionally long dome light delay circuits.

2-7 IGNITION-CONTROLLED DOMELIGHT SUPERVISION ON/OFF: If turned on, the system will turn on the dome-light for 30 seconds when the ignition is turned off. The optional domelight supervision feature must be installed.

2-8 DOUBLE PULSE UNLOCK ON/OFF: Some vehicles require two pulses on a single wire to unlock the doors. When the double pulse unlock feature is turned on, the BLUE H2/C wire will supply two negative pulses instead of a single pulse. At the same time, the GREEN H2/A wire will supply two positive pulses instead of a single pulse. This makes it possible to directly interface with double pulse vehicles without any extra parts.

2-9 CHANNEL 3 VALIDITY/LATCHED/LATCHED RESET WITH IGNITION/30 SECOND TIMED/SECOND UNLOCK OUTPUT: Channel 3 can be programmed for these output configurations. The unit is set to the default validity output. To change the configuration, use the two-chirp setting to toggle to the different configurations.

transmitter /receiver learn routine

The system comes with two transmitters that have been taught to the receiver. The receiver can store up to 4 different transmitter codes in memory. Use the following learn routine to add transmitters to the system or to change button assignments if desired.

Using the optional DEI Bitwriter or PC Interface, the learn routine may be locked. Make sure the learn routine is unlocked before programming features. If the siren generates one long chirp when attempting to program the unit, the learn routine is locked and must be unlocked using the DEI Bitwriter or PC before proceeding.



1. **Open a door:** (The GREEN wire, H1/5, or the VIOLET, H1/7 must be connected.)



2. **Turn the ignition on:** (The YELLOW wire, H1/9 must be connected.)



3. **Select the receiver channel:** Press and release the Valet®/Program button the number of times necessary to access the desired channel.

NOTE: If adding a remote, a button must be taught to the unit in the Channel 1 or Channel 4 position prior to programming other channels.

Press and hold the Valet®/Program button once more. The siren will chirp and the LED will blink the number of times corresponding to the channel that is accessed.

CHANNEL NUMBER	FUNCTION	WIRE COLOR
1	Arm/Disarm/Panic	
2	Silent Mode™/Remote Valet®/Trunk Release	RED/WHITE
3	Remote Start or other accessories	WHITE/BLUE
4	Arm only	
5	Disarm only	
6	Panic only	
7	Auto Learn Standard Configuration*	
8	Auto Learn Single Button Arm/Disarm Configuration*	
9	Delete all transmitters	

***NOTE:** For Auto Learn Configurations, see Transmitter Configurations section of this guide.

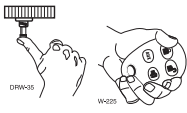

4. **Press the transmitter button:** While holding the Valet®/Program switch, press the button from the transmitter that you wish to assign to the selected channel. The unit will chirp indicating successful programming. It is not possible to teach a transmitter button to the system more than once.

Channels #4-6: Channels 4 through 6 are used to assign the arm, disarm and panic functions to separate buttons on the remote control. Teaching a button to Channel 4 erases all information about that remote from memory. Any auxiliary functions that are desired will have to be reprogrammed. Similarly, if the remote is set up to use the separate arm, disarm and panic channels and a button from that remote is entered into channel one, the remote will be erased from memory, and the system will only recognize the button that was entered into channel one.

Channel #9: If any transmitter button from a known transmitter is programmed to Channel 9, all transmitters will be erased from memory. This is useful in cases where the one of the customer's transmitters is lost or stolen. This will erase any lost or stolen transmitters from the system's memory. It can also be used to start from scratch if the transmitter buttons were programmed incorrectly.



5. **Release:** Once the code is learned, the Valet®/Program button can be released.

Learn Routine™ will be exited if:

- Ignition is turned off.
- Door is closed.
- Valet®/Program button is pressed too many times.
- More than 15 seconds elapse between steps.





One long chirp indicates that Learn Routine™ has been exited.

transmitter configurations

The transmitters can be programmed with the standard or single button arm/disarm configurations by using the Auto Learn functions in the Transmitter/Receiver Learn Routine.

standard configuration



A remote that uses the standard configuration operates similarly to many factory keyless entry remotes. A standard configuration transmitter allows arming, disarming, and Panic Mode activation with separate buttons. When programmed for standard configuration, the transmitter buttons are assigned to the following functions:

-  operates Arm only
-  operates Disarm only
- AUX** operates Channel 2
-  operates Panic
-  and  operate Channel 3

The standard configuration also allows the user to utilize Multi-Level Security Arming (described in the following section), a feature that cannot be accessed from a single button arm/disarm configuration transmitter.





single button arm/disarm configuration

When programmed for single button arm/disarm configuration, the transmitter buttons are assigned to the following functions:

-  operates Arm/Disarm/Panic
-  operates Channel 2
- AUX** operates Channel 3

multi-level security arming

Multi-Level Security Arming is a feature that allows you to select which of the security system's inputs or sensors will be active and which will be bypassed at the time that the system is armed. (See *Table of Zones* section in this guide.) Pressing the arm button (only on a Standard Configuration transmitter) again within five seconds of arming the security system will activate the Multi-Level Security Arming feature. Each time the arm button is pressed again, a different security level is selected. The different security levels can be selected as follows:

- Pressing  one time: The siren chirps once. The system is armed.
- Pressing  a second time within five seconds: The siren chirps twice followed by a long chirp. Zone Two is now bypassed.
- Pressing  a third time within five seconds: The siren chirps three times followed by a long chirp. Zone Four is now bypassed.
- Pressing  a fourth time within five seconds: The siren chirps four times followed by a long chirp. Zones Two and Four are now bypassed.
- Pressing  a fifth time within five seconds: The siren chirps five times followed by a long chirp. All input zones, except the ignition, are now bypassed.

NOTE: Multi-Level Security Arming only applies to a single arming cycle. Once the system is disarmed and then re-armed, all the zones will be active again.

table of zones

ZONE NO.	TRIGGER TYPE	INPUT DESCRIPTION
1	Instant	H1/6 BLUE wire. Connect to optional hood/trunk pins.
2	Multiplexed	Blue wire of plug-in shock sensor. Inputs shorter than 0.8 seconds will trigger a Warn Away response, while inputs longer than 0.8 seconds will instantly trigger full alarm sequence.
3	Two-stage, progresses from warning to full alarm	Door switch circuit. H1/5 GREEN or H1/7 VIOLET.
4	Multiplexed Input	GREEN wire of plug-in shock sensor. Inputs shorter than 0.8 seconds will trigger a Warn Away response, while inputs longer than 0.8 seconds will instantly trigger full alarm sequence.
5	Two-stage (similar to doors)	Ignition input. H1/9 YELLOW.

NOTE: The Warn Away® response does not report on the LED.

long term event history

The system stores the last two full triggers in memory. These are not erasable. Each time the unit sees a full trigger, the older of the two triggers in memory will be replaced by the new trigger. To access long term event history:



1. With the ignition off, press and hold the Valet®/Program switch.



2. Turn on the ignition.



3. Release the Valet®/Program switch.

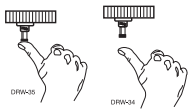

4. Press and release the Valet®/Program switch within 5 seconds. The LED will flash in groups indicating the last two zones that triggered the unit. The LED will flash for one minute or until the ignition is turned off.

NOTE: The Warn Away® triggers are not stored to memory and will not be reported.

optional vehicle recovery system (VRS®)

No additional parts are required to add the optional VRS® feature. However for the VRS® feature to be effective, the 8618 Starter Kill Relay must be installed. The VRS® feature can be activated with the remote transmitter and deactivated with the valet switch. If the VRS® option is selected it is recommended to program the Valet switch to respond to more than one pulse for maximum security. (See *System Features Learn Routine* section of this guide.)

to arm VRS



1. Turn the ignition to the ON position.



2. Press the lock button on the transmitter for 1 second. The parking light will flash once and the siren will chirp once to confirm that the VRS system is armed and will enter the trigger sequence next time a door is opened and then closed.

to disarm VRS

To disarm VRS (before siren begins chirping):



1. Turn the ignition to the ON position.



2. Press the unlock button on the transmitter for 1 second. The parking lights will flash twice and the siren will chirp twice to confirm that the VRS® system is disarmed.

To disarm VRS (after siren has begun chirping):



1. Turn the ignition to the ON position.



2. Press and release the Valet®/Program switch the selected number of times programmed in Step 2-5. (See *System Features Learn Routine* section of this guide.)

NOTE: For a detailed explanation to the VRS triggered sequence, refer to the *Vehicle Recovery System* section of the *Owner's Guide*.

rapid resume logic

The Rapid Resume Logic feature ensures that when the security system is powered back up after power has been disconnected, the system will resume the same state it was in before power was lost. For example, if power is disconnected during a full trigger sequence, the system will still be in the full trigger sequence when power is reconnected to the unit. If power is disconnected while the unit is disarmed, it will still be disarmed when power is restored. This also applies to the VRS sequence. If the unit loses power at any time during the VRS sequence, it will automatically resume the VRS full trigger sequence when the unit is powered back up.

troubleshooting

■ Starter kill doesn't work.

Is the correct starter wire being interrupted? If the car starts when the starter kill relay is completely disconnected, the wrong starter wire has been cut and interrupted.

Yellow wire is not connected to true ignition. It is connected to an accessory circuit.

■ Shock sensor doesn't trigger the alarm.

Has the NPC™ system been triggered? If so, you will hear five chirps when disarming. To check this, turn the ignition key on and off to clear the NPC™ from memory, and then retest the shock sensor. For a detailed description of NPC™, see Owner's Guide.

■ Door input does not immediately trigger full alarm. Instead, I hear chirps for the first three seconds.

That's how the progressive two-stage door input works! This is the instant response feature of this system. Even if the door is closed immediately, the system provides an instant trigger by chirping, and the progressing to a constant siren.

■ Closing the door triggers the system, but opening the door does not.

Have you correctly identified the type of door switch system? This happens often when the wrong door input has been used.

■ System will not passively arm until it is remotely armed and then disarmed.

Are the door inputs connected? Is a blue wire connected to the door trigger wire in the vehicle? Either the green H1/5 or the violet H1/7 should be used instead.

■ Door input does not respond with the progressive trigger, but with immediate full alarm.

What zone does the LED indicate? If the LED indicates that the impact sensor caused the trigger, the sensor may be detecting the door opening. Reducing the sensitivity or relocating the sensor can often solve this problem. If the LED indicates that the door caused the trigger, you may have programmed the progressive door trigger off. (See Feature 2-4 in the *Feature Descriptions* section of this guide.)

■ The Valet® switch doesn't work.

Is it plugged into the correct socket?

Check the System Features Learn Routine for the programmed Valet pulse count.

■ Status LED doesn't work.

Make sure that it is plugged in. (See *Plug-In Harnesses* section of this guide.) Is the LED plugged into the correct socket?

